

REAR

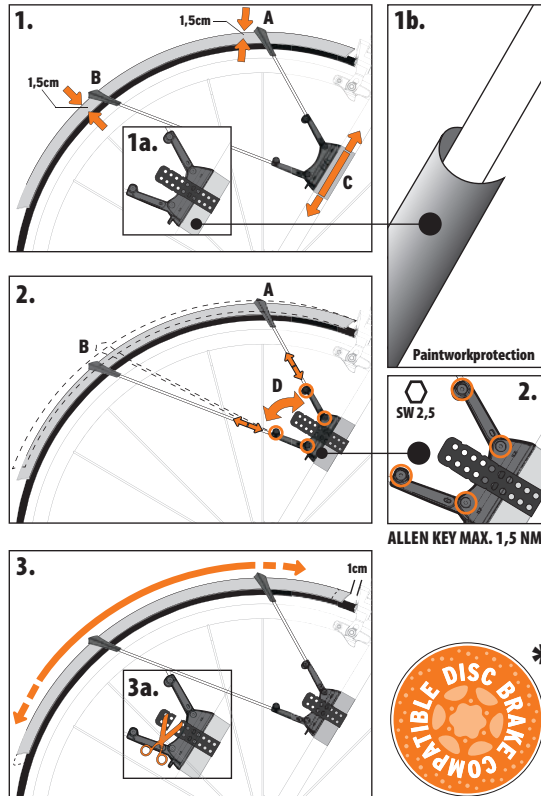

FRONT (STANDARD FORK)

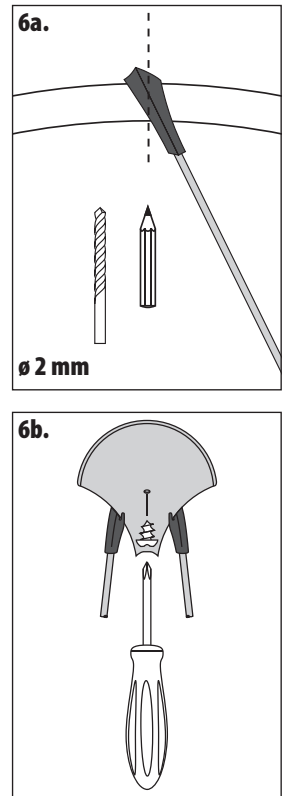
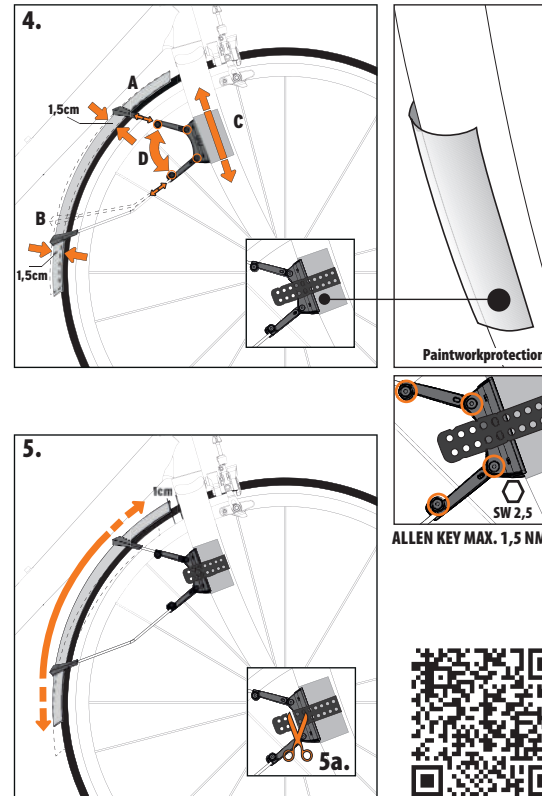

EN. INSTRUCTIONS FOR USE

The SKS **RACEBLADE PRO** is an ultra-light wheel protection set boasting excellent splash protection, especially for racing wheels and crossbike wheels. The Raceblade can be assembled in a very short space of time thanks to the simple SKS quick assembly system. The **RACEBLADE PRO** is available in two different widths:

RACEBLADE PRO: For racing wheels with a max. tyre width of up to 25 mm

RACEBLADE PRO XL: For racing wheels and crossbike wheels with a tyre width of between 25-32 mm

Rear assembly:

- 1 Align the wheel protector facing upwards in such a manner that the distance to the tyre on the front strut (A) is a minimum of 1.5 cm whilst the strut is in contact with the fastening points on the frame. In order to determine the correct distance, move the strut holder upwards or downwards on the frame. (Arrow C) The distance between the wheel protector and the tyre should now also amount to 1.5 cm on the strut (B). If the distance is higher or lower, the strut must be adjusted to its frame shape.
- 1a In order to do so, first attach the strut to the seating struts of its frame on each side with the of clamping rubber by hooking the clamping rubber into the fastening points. Clamp the rubber so tightly that it is impossible for the strut to slip on the frame.
- 1b If necessary, use the enclosed paintwork protection in order to protect the frame. Please see the section entitled »Permanent attachment of the wheel protector« for information regarding the permanent attachment of the wheel protectors with the enclosed cable ties.
- 2 The distance between the strut (B) and the tyre can be adjusted by changing the inclination of the struts (D). Loosen the four Allen screws belonging to the connection and move the strut into the correct position. Check the distance between the wheel protector and the tyre once again.
- 3 Finally ensure that the clearance between the mudguard and the brake and frame respectively has been correctly adjusted. It should be at least 1 cm. Adjust the clearance if necessary by shifting the profile in the strut brackets.
- 3a Where necessary, carefully shorten the clamping rubbers with scissors so that the ends cannot come into contact with the wheel spokes.

Front assembly:

- 4 As was the case with the rear wheel, first check whether the struts need to be adjusted to match the shape of the forks. Pay attention to an even distance of at least 15 mm between the mudguard and the tyre respectively 10 mm between mudguard and downtube along the entire length of the profile. Where necessary, adjust the inclination of the struts as described under Point 2.
- 4a If necessary, use the enclosed paintwork protection in order to protect the forks.
- 5 Distance between the profile and the forks
The distance to the forks should amount to a minimum of 1 cm. The distance to the forks can be regulated by moving the profile in the strut brackets. Ensure that the distance to the wheel protector is sufficient when the pedal is in the front position.
- 5a You can also carefully shorten the clamping rubber here using scissors where necessary.

Permanent attachment of the wheel protectors

In order to fasten with the quick-release clamping rubbers, the **RACEBLADE PRO** wheel protectors can also be attached with cable ties. This type of fastening is only suitable for the permanent fastening of the **RACEBLADE** on the wheel. In order to assemble, use a further 2 cable ties per side in addition to the clamping rubbers. Ensure that the cable ties run precisely in the grooves provided for this purpose. Pull the cable ties as tight as possible so that slipping cannot occur. Carefully cut the protruding ends of the cable ties using scissors.

Safety information!

Before each journey, check that the wheel protectors are sitting correctly. If the minimum distance between the wheel protector and the tyre is not observed, the wheel protector may become damaged and, in the worst case scenario, could lead to a crash. Therefore, it is essential that the minimum distance of 1.5 cm is observed during assembly. Ensure that the flawless function of the brakes is guaranteed and that the wheel protector does not come into contact with the moving brake parts. Due to the effect of UV radiation, the clamping rubbers are subject to natural ageing. Regularly check the condition of the clamping rubbers and promptly replace them in the event of damage.

Pro advice

If the wheel protectors are correctly set, the profiles can be permanently screwed together with the strut brackets. In order to do so, remove the fully adjusted wheel protectors from your wheel once again.

- 6a In order to make this process easier, we recommend pre-drilling a 2 mm hole in the respective position.
- 6b Now screw the enclosed screws through the profile and into the drill hole of the strut bracket.

* Disc brake compatible: please check brake cable routing.

WARNING! SKS is not responsible for damage to frame paint or carbon resulting from use of this product. Proper use of protection film and maintenance, including regular cleaning of frame and fender at attachment points, will prevent such damage.