

***DT* SWISS**

350 / 370 FRONT WHEEL HUBS
TECHNICAL MANUAL

V2020.12

1. GENERAL	3
1.1 Validity.....	3
1.2 Safety	3
1.3 Target group.....	3
1.4 Layout.....	3
1.5 DT Swiss manual concept	3
1.6 How to use the manual	4
1.7 General maintenance information.....	4
1.8 Environmental protection.....	4
1.9 Exclusion of liability.....	4
1.10 Warranty.....	4
2. SERVICING THE FRONT HUB 350 THRU AXLE.....	5
2.1 Overview.....	5
2.2 Required tools.....	6
2.3 Required wearing parts and materials.....	6
2.4 Removing pressed-on end caps.....	7
2.5 Removing the plugged-in end caps	8
2.6 Cleaning and degreasing all parts.....	8
2.7 Mounting ball bearing and spacer.....	9
2.8 Attaching pressed-on end caps	13
2.9 Attaching plugged end caps.....	14
3. SERVICING THE FRONT HUB 350 QR	15
3.1 Overview.....	15
3.2 Required tools.....	15
3.3 Required wearing parts and materials.....	15
3.4 Removing the end caps	16
3.5 Dismounting the Bearings and the Axle.....	17
3.6 Cleaning and degreasing all parts.....	17
3.7 Mounting bearings and axle.....	18
3.8 Putting on the end caps	19

1. GENERAL

1.1 VALIDITY

This manual describes the component specified on the front page and the footer. This manual is valid for the design of the product as of 04.01.21. Deviations are possible and all items are subject to technical changes.

1.2 SAFETY

The safety instructions are classified as follows:



DANGER

...indicates a hazardous situation that, if not avoided, will result in death or serious injury.



CAUTION

... indicates a hazard with a medium level of risk which, if not avoided, may result in minor or moderate injury.



NOTICE

... indicates a potentially hazardous situation that may result in damage to property.

1.3 TARGET GROUP

This manual is intended for the user of the component and dealers. This manual offers the experienced user the possibility to carry out minor service work himself. If you have any doubts about your own abilities, you should definitely contact a specialist or a DT Swiss Service Center.

Any warranty claims will lapse if work is not carried out properly.

1.4 LAYOUT

The cover page and the footing provide information about the type of product and manual as well as the version of the manual. The DT Swiss contact details can be found on the back. A list of all DT Swiss service centers can be found at www.dtswiss.com.

This manual is intended for being printed as an A5 booklet. Only print this manual if electronic usage is not possible.

1.5 DT SWISS MANUAL CONCEPT

The DT Swiss manuals are split into the following types of manuals:

- User Manual: Information for the end user on how to install and use the component.
- Technical Manual: Detailed information for the end user and the dealer on how to maintain the component, spare parts and technical data.

1.6 HOW TO USE THE MANUAL

The steps described in this manual must be carried out in the order they are shown. If steps are ignored or executed in a wrong order, the function of the component cannot be guaranteed.

1.7 GENERAL MAINTENANCE INFORMATION

Unless otherwise specified, moving parts, threads, O-rings and seals must be greased before assembly.

CLEANING

For an optimal result of the maintenance works, every component that will be disassembled must be cleaned. Only use cleaners which do not damage the components. Especially the cleaning of O-rings and seals requires mild cleaners. Observe the instructions for use of the respective cleaner.

DT Swiss recommends the following cleaners:

- Motorex Rex
- Motorex Swissclean
- Motorex OPAL 2400, 3000 OPAL, OPAL 5000

Use soap water or similar mild cleaners for external cleaning.

TOOLS

To ensure a damage-free mounting and dismantling of the components, only use the tools which are mentioned in this manual. Special tools are indicated at the beginning of a chapter in the table "Required material".

The use of different tools is at the discretion of the user. If components are damaged by the usage of differing tools, the user is liable.

DT Swiss special tools are precision tools. Damage-free mounting and dismantling of the components can only be ensured if the tools are working properly and if the condition of the tools are perfect. Always keep the tools in their original packaging or adequate devices to prevent damage.

1.8 ENVIRONMENTAL PROTECTION

The statutory regulations shall apply. Whenever possible, avoid creating waste. Waste, especially carbon, lubricants, cleaners and any other fluids must be disposed in an environmentally compatible manner. Only print this manual if electronic usage is not possible.

1.9 EXCLUSION OF LIABILITY

The activities listed in this manual may only be carried out by persons with sufficient specialist knowledge. The user is liable for any damage or consequential damage caused by wrongly maintained or installed components. If you have doubts, please contact your region's DT Swiss pro level service center.

1.10 WARRANTY

Warranty conditions, see www.dtswiss.com

2. SERVICING THE FRONT HUB 350 THRU AXLE

Preparatory Steps:

Link

Dismount the brake rotor

Clean the hub

2.1 OVERVIEW

OVERVIEW 350 THRU AXLE WITH PRESSED-ON END CAPS

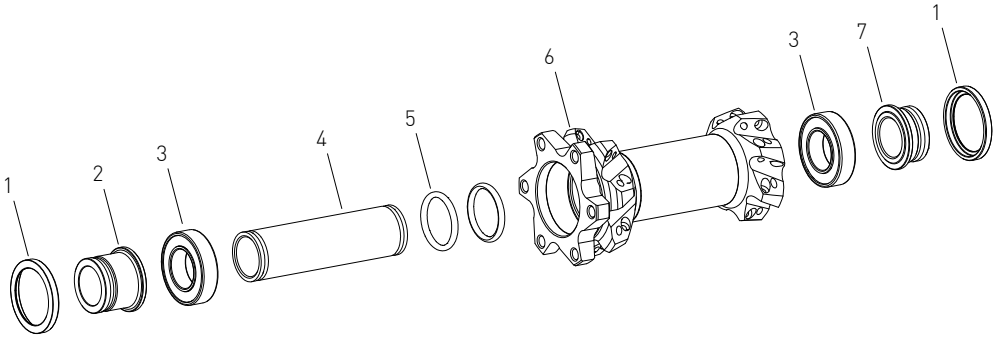

1 cover	4 spacer	7 end cap drive side
2 end cap non drive side	5 O-ring	
3 ball bearing	6 hub shell	

OVERVIEW 350 THRU AXLE WITH PLUGGED END CAPS

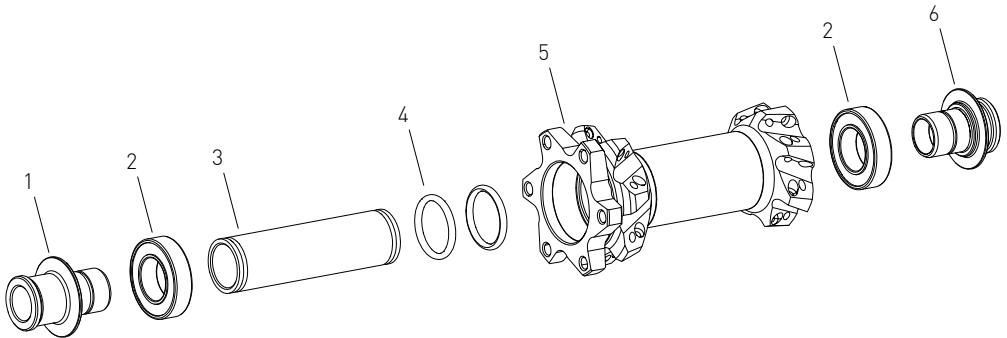

1 end cap non drive side	3 spacer	5 hub shell
2 ball bearing	4 O-ring	6 end cap drive side

2.2 REQUIRED TOOLS

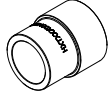
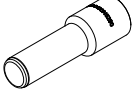
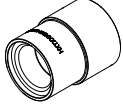
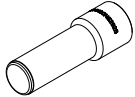
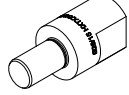
Tools	Specification	Quantity	Article number
Tool set 350 Ø15 mm, includes		1	HWTXXX00N5290S
	<ul style="list-style-type: none"> • installation cylinder Ø28 mm 		1
	<ul style="list-style-type: none"> • mounting pin Ø15 mm 		1
Tool set 350 Ø20 mm, includes		1	HWTXXX00N5292S
	<ul style="list-style-type: none"> • installation cylinder Ø37 		1
	<ul style="list-style-type: none"> • mounting pin Ø20 mm 		1
mounting tool		2	HXTXXX00N9793S

2.3 REQUIRED WEARING PARTS AND MATERIALS

Wearing parts / Materials	Specification	Quantity	Article number
DT Swiss universal grease		20 g	HXTXXX00NMG20S

Due to the large variety of spare parts, they cannot be listed here.

At dtswiss.com/support/product-support you will find all suitable spare parts after selecting your components.

2.4 REMOVING PRESSED-ON END CAPS



NOTICE

RISK OF DAMAGE TO THE END CAPS AND THE BALL BEARINGS!

The mounting pin must not touch the ball bearing while the end caps are being levered out.

1. Insert the mounting pin into one of the end caps.
→ Risk of damage: see note!
2. Push the mounting pin downwards (see picture).

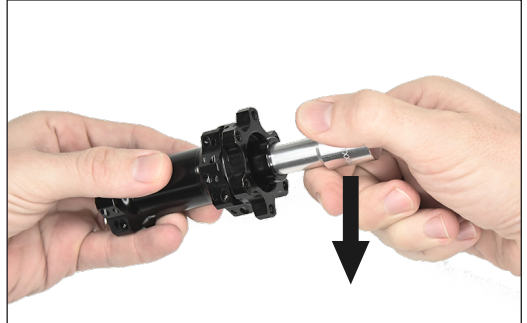

3. Remove end cap and cover.



2.5 REMOVING THE PLUGGED-IN END CAPS

1. Clamp one of the end caps into a vise.
2. Pull off the wheel, respectively the hub.
3. Clamp the second adapter into the vise.
4. Pull off the wheel, respectively the hub.



DISMOUNTING BALL BEARING AND SPACER

1. Press the spacer slightly aside and carefully tap out the ball bearing on the drive side with a suitable punch.
2. Turn the hub by 180°.
3. Place the large diameter of the mounting pin on the spacer.
4. Tap out the ball bearing on the non drive side.

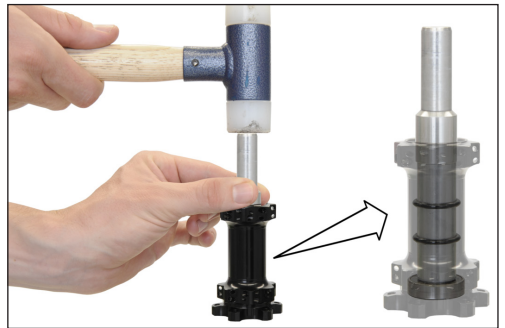
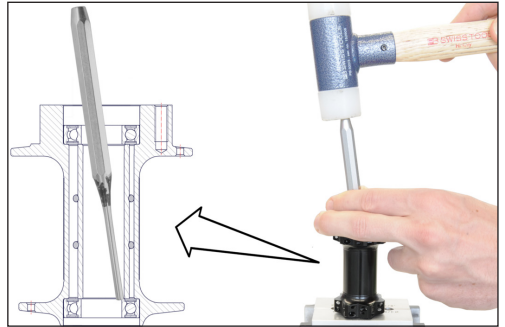

2.6 CLEANING AND DEGREASING ALL PARTS

Clean all parts of the hub (see Cleaning, page 5)

2.7 MOUNTING BALL BEARING AND SPACER

1. Grease the inner surface of the hub shell and especially the bearing seats with universal grease.

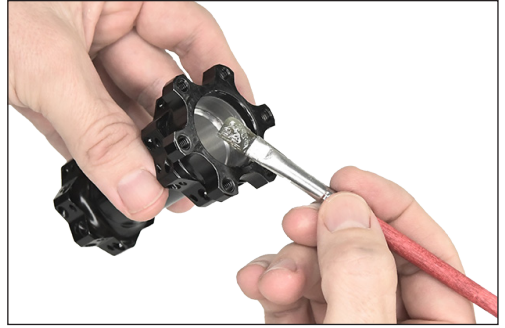

2. Clamp the mounting tool into a vise.
3. Push the spacer onto the mounting tool.



4. Push the drive side of the hub shell onto the mounting tool.

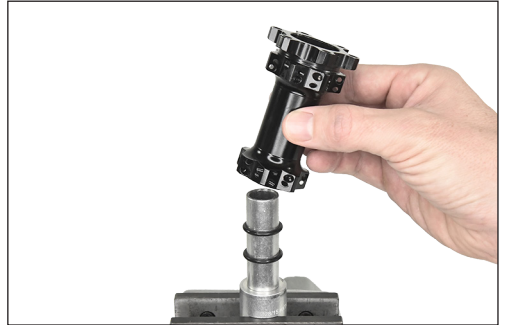

5. Fit the ball bearing onto the hub with the coloured side facing outwards.



6. Attach the second mounting tool to the non drive side.



7. Tap in the ball bearing with a plastic hammer.



8. Turn the hub by 180° and place it on the mounting tool.



9. Push the spacer with O-rings into the hub.



10. Place a new ball bearing on the bearing seat with the coloured side facing outwards.



11. Fit the mounting tool onto the ball bearing.



12. Tap in the ball bearing with a plastic hammer.



13. Check the ball bearings.

- The hub must turn smoothly.
- The spacer must not be loose between the ball bearings.

14. If necessary, drive in the bearing on the non drive side or loosen the bearing.

15. Repeat previous steps until the hub is turning smoothly.



2.8 FITTING PRESSED-ON END CAPS

1. Grease the bearings and the inner surface of both end caps.



2. Fit one of the two end caps and the cover onto the hub.
The longer end cap must be placed on the non drive side.



3. Push on the installation cylinder.
 - end cap non drive side: Attach the installation cylinder with the small diameter.
 - end cap drive side: Attach the installation cylinder with the large diameter.



4. Insert the mounting pin into the tool.

5. Tap the cover onto the hub shell.
6. Repeat the procedure for the second end cap.



2.9 FITTING PLUGGED END CAPS

1. Grease the bearings and the inner surface of both end caps.



2. Push one of the two end caps on the hub.
The longer end cap must be placed on the non drive side.



3. Press the end cap into the hub by hand.



4. Repeat the procedure for the second end cap.

Closing Steps:

Mount the brake rotor

[Link](#)

3. SERVICING THE FRONT HUB 350 QR

Preparatory Steps:

Link

Clean the hub

3.1 OVERVIEW

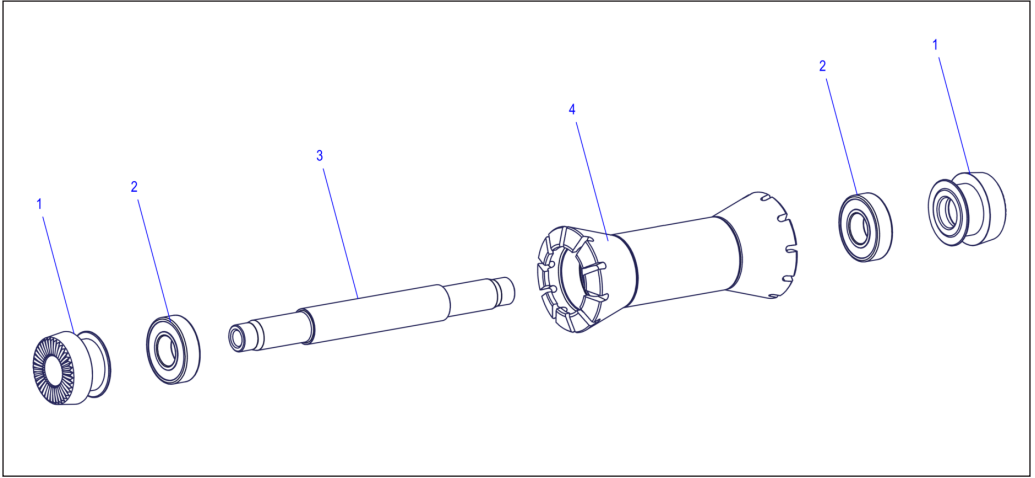

1 end cap

3 axle

2 ball bearing

4 hub shell

3.2 REQUIRED TOOLS

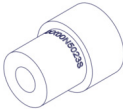
Tools	Specification	Quantity	Article number
installation cylinder		2	HXTXXX00N5023S

3.3 REQUIRED WEARING PARTS AND MATERIALS

Wearing parts / Materials	Specification	Quantity	Article number
DT Swiss universal grease		20 g	HXTXXX00NMG20S

Due to the large variety of spare parts, they cannot be listed here.

At dtswiss.com/support/product-support you will find all suitable spare parts after selecting your components.

3.4 REMOVING THE END CAPS

1. Lever off the end caps by a few millimeters using a small screwdriver or similar suitable tool.



2. Remove the end caps from the hub by hand.



3.5 DISMOUNTING THE BEARINGS AND THE AXLE

1. Tap out ball bearing. To do this, hit the axle with a plastic hammer.



2. Remove the ball bearing from the axle.



3. Push the axle through the second ball bearing.
4. Repeat steps on second ball bearing

3.6 CLEANING AND DEGREASING ALL PARTS

Clean all parts of the hub (see Cleaning, page 5)

3.7 MOUNTING BEARINGS AND AXLE

1. Grease the inner surface of the hub shell and bearing seats.



2. Insert the axle into the installation cylinder.
3. Push the hub shell onto the installation cylinder and axle.
For hubs with disc brake mount, the ball bearing on the non drive side must be mounted first.
4. Push a new bearing on the axle and the hub shell with the colored side facing outwards.



5. Fit the second installation cylinder onto the ball bearing and tap in the ball bearing.



6. Turn hub 180° and repeat step 3 to step 5 on the second side of the hub.
7. Check the play of the hub. To do this, hold the hub and move the axle axially.
 - The axle must not have any play!
8. If play is noticeable, tap in the ball bearing.
 - For hubs with disc brake mount, tap in the bearing on non drive side first.
9. Check the running of the ball bearings. To do this, hold the axle firmly and turn the hub shell.
 - The hub must turn smoothly.



10. If the hub runs sluggishly, loosen the ball bearings slightly by tapping the axle lightly with a hammer.
 - For hubs with disc brake mount, slightly loosen the ball bearing on the drive side.

3.8 PUTTING ON THE END CAPS

1. Grease the bearings and the inner surface of both end caps.



2. Push the end caps onto the hub by hand. For hubs with disc brake mount, the longer end cap must be fitted on the non drive side.



Closing Steps:

not required

Link

DT SWISS AG

Längfeldweg 101
CH - 2504 Biel/Bienne
info.ch@dtswiss.com

DT SWISS, INC.

2493 Industrial Blvd.
USA - Grand Junction, CO 81505
info.us@dtswiss.com

DT SWISS (FRANCE) S.A.S.

Parc d'Activites de la Sarrée
Route de Gourdon
F - 06620 Le Bar sur Loup
info.fr@dtswiss.com

DT SWISS ASIA LTD.

No.5, Jingke 5th Rd., Nantun District
Taichung City 408
Taiwan (R.O.C.)
info.tw@dtswiss.com

DT SWISS DEUTSCHLAND GmbH

Albert-Einstein-Strasse 3
59302 Oelde
Germany
info.de@dtswiss.com

DT SWISS POLSKA Sp. z o.o.

ul. Towarowa 36
PL-64-600 Oborniki
Poland
info.pl@dtswiss.com

Subject to technical alterations, errors and misprints excepted.

All rights reserved.

© by DT SWISS AG

www.dtswiss.com

HXD10000004013S